

Product Information Sheet



FyreWrap® Cable Insulation

Introduction

Alkegen's FyreWrap® Cable Insulation is a thin, flexible, insulation wrap designed to provide a fire-protective enclosure around cable trays and conduit. The FyreWrap system ensures electrical circuit integrity during exposure to an external hydrocarbon fire, permitting continued operation or controlled shutdown of critical equipment during emergency conditions. This system is FM Global Approved and meets ASTM E1725 "Fire Tests of Fire-Resistive Barrier Systems for Electrical System Components," requiring the highest level of performance for trays with zero to full cable loading. The system also meets ASTM E1529 and provides circuit integrity ratings. FyreWrap complies with many industry specifications on fireproofing for petroleum and petrochemical processing plants.



Product Components

FyreWrap Cable Insulation incorporates Insulfrax® Blanket as its insulating core. This is a high temperature AES (alkaline earth silicate) Wool blanket, that is exonerated from classification by virtue of Note Q, as detailed under regulation (EC) No 1272/2008 (CLP) and as such is considered to be a low biopersistent (LBP) substance. (These materials have been designed to allow rapid clearance from the lung, following inhalation). It provides excellent insulation and is fully non-combustible. The core insulation is completely encapsulated in a choice of coverings:

- A 50µm aluminium foil reinforced with a bi-directional glass fibre mesh. This covering has excellent tear resistance and enhanced handling characteristics & imparts weather and UV resistance to the system. Recommended for outdoor use where no additional cladding is to be used.
- An aluminum foil, fiberglass-reinforced scrim covering. This scrim provides additional handling strength as well as protection from tearing and moisture absorption. Recommended for indoor use or where additional protective cladding is to be used.



Typical Product Parameters

Thickness	1.5", 2.0" (38mm, 50mm)
Density	8pcf (128kg/m ³)
Standard Product Form	Encapsulated Insulation
Product Availability	1.5" x 24" w x 25 LF (38mm x 610mm x 5000mm)
	1.5" x 48" w x 25 LF
	2" x 24" w x 20 LF (50mm x 610mm x 3660mm)
	2" x 48" w x 20 LF

Product availability may differ depending on location, please check with your Alkegen representative.



Refer to the product Material Safety Data Sheet (MSDS) for recommended work practices and other product safety information.



Product Information Sheet



FyreWrap® Cable Insulation

Typical System Properties

- FM Global Approved – Wrap for Grouped Electrical Cables
- Fire Ratings – 15, 30, 45 and 60 minutes (contact Alkegen for details)
- Fire Exposure – Hydrocarbon Fire per ASTM E1529
- Temperature Integrity – per ASTM E1725
- Cable Loading – Empty to Fully Loaded Trays
- ASTM E84 Surface Burning Characteristics:
 - Unfaced Core: Flame/Smoke Rating = Zero
 - FyreWrap: Flame/Smoke Rating < 25/50

Figure 1. Single-Layer System Installation

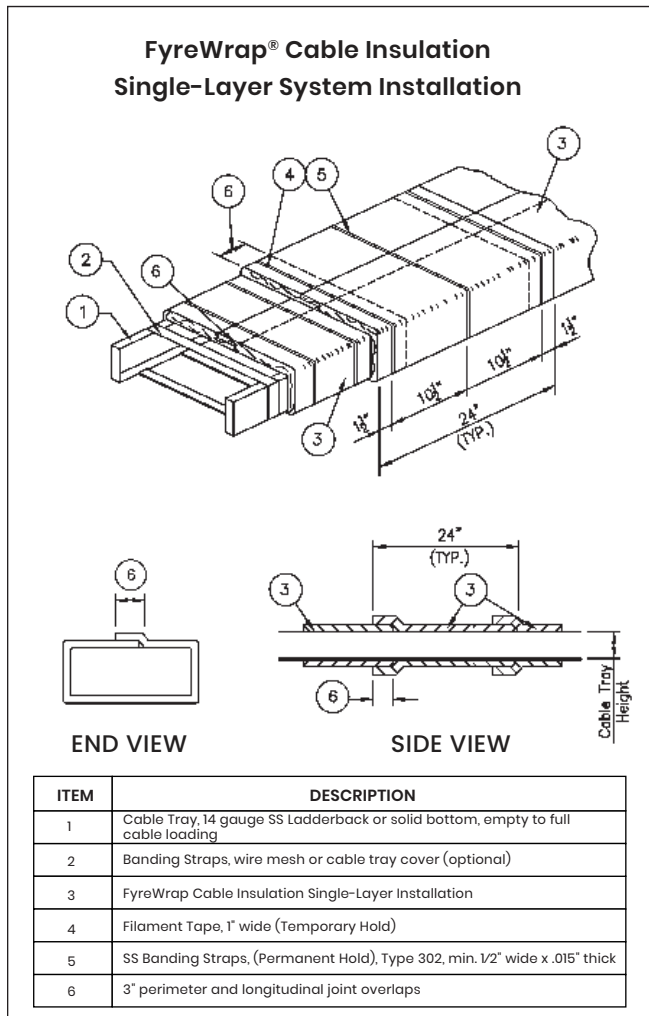

Installation

To prevent material sagging on open cable trays (no lids), steel banding is installed around the cable tray perimeter prior to application of the insulation blanket. Banding is tightened to create a surface for the insulation blanket to rest upon. The use of wire mesh or a cable tray lid is also permitted.

Single-Layer System:

The FyreWrap Cable Insulation single-layer systems are applied directly around the exterior perimeter of the cable tray. All material overlaps must be a minimum 3". To minimize waste, FyreWrap should be rolled out tautly before measuring. Cut the insulation to a length sufficient to wrap around the tray plus a minimum 3" longitudinal material overlap. Seal all cut edges with aluminum foil tape to ensure there is no exposed fiber. Adjacent pieces of insulation must overlap onto the previous piece to form a minimum 3" perimeter material overlap.

Once the insulation blanket is in place, it may be temporarily secured with the optional use of 1" wide filament tape. Locate the tape within 1.5" of the insulation edge and in the center of the insulation blanket width. Stainless steel banding (min. 0.5" wide, min. 0.015" thick) must be utilized on the outside of the insulation as a permanent attachment. Center bands over the material overlaps, approximately 1.5" from the insulation edge. An additional band shall be located within the field between overlaps, approximately 10.5" on center. This band spacing should be used for straight cable tray runs and on bends. Utilize band tensioning tools and crimp clips to tighten the banding around the insulation and secure in place. See Figure 1 for details.



Product Information Sheet



FyreWrap® Cable Insulation

Figure 2. Two-Layer System Installation

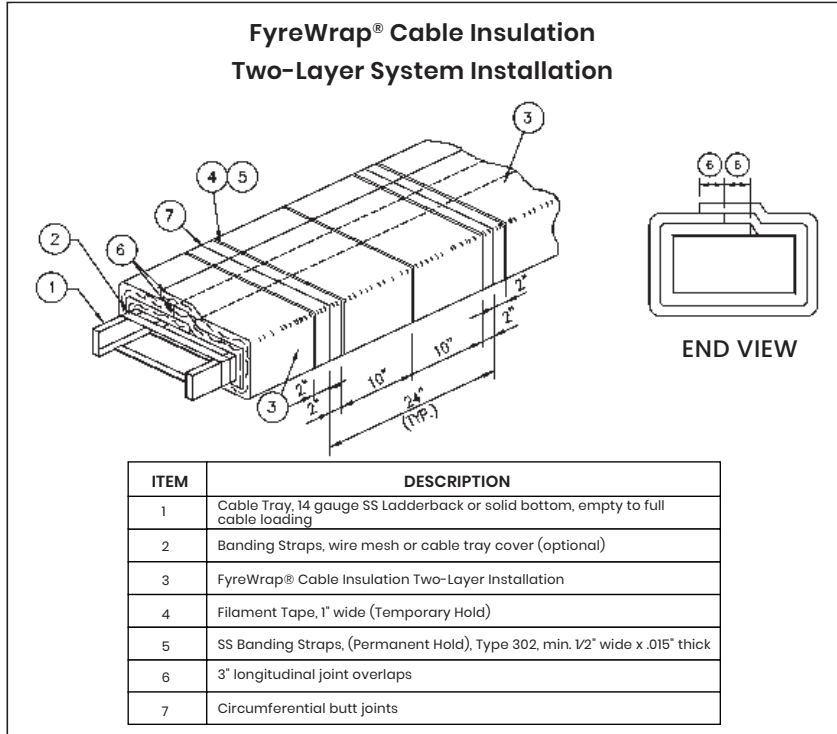

Two-Layer System:

The FyreWrap Cable Insulation two-layer system is applied directly around the exterior perimeter of the cable tray. All perimeter material overlaps utilize a compression butt joint. All longitudinal material seams are overlapped a minimum 3". To minimize waste, FyreWrap should be rolled out tautly before measuring. Seal all cut edges with aluminum foil tape to ensure there is no exposed fiber. Once the insulation is in place, it may be temporarily secured with the optional use of 1" wide filament tape. Locate the tape 2" from the insulation perimeter butt joint and in the center of the insulation blanket width, approximately 10" on center. Stainless steel banding (min. 0.5" wide, min. 0.015" thick) must be utilized on the outside of the insulation as a permanent attachment. Locate bands 2" from the perimeter insulation butt joint and in the blanket width between bands, approximately 10" on center. This band spacing should be used for straight cable tray runs and on bends. Utilize band tensioning tools and crimp clips to tighten the banding around the insulation and secure in place. See Figure 2 for details

Testing Results

For additional information on FyreWrap Cable Insulation, fire test results, independent laboratory certifications or compliance to industry specifications, please contact the Alkegen Application Engineering Group at 716-768-6298.



Product Information Sheet



FyreWrap® Cable Insulation

Other Fire Protection Products and Applications

Alkegen offers many UL-listed Fiberfrax® and FyreWrap® product forms and FyreWrap fire protection materials for passive fire protection applications, such as:

Product	UL File Number
FyreWrap® Duct Insulation	R14514
Insulfrax® S Blanket	R14514
Fiberfrax® XFP® – Expanding Fyre Paper	R15435
Fiberfrax® Durablanket® Ceramic Fiber Blanket	R14514
Fiberfrax® Duraboard® Ceramic Fiber Board LD	E75289
Fiberfrax® Ceramic Fiber Papers (110/440)	E75289
Fiberfrax® Ceramic Fiber Papers (970)	MH7030
Fiberfrax® Lo-Con™ Felt	MH7030
Fiberfrax® Moist Pak-D®	E75289

These products offer solutions in applications such as:

- Grease, HVAC Ducts
- Cable Trays, Conduit
- Control System Covers
- Above Ground Storage Tanks
- Marine Bulkheads, Decks
- Structural Steel
- Construction Joints
- Curtain Walls/Safing
- Circuit Protection
- Railroad Tank Cars
- Transit Cars
- Ships
- Expansion Joints
- Fire Door Seals
- Chimney Liners
- Ceiling Air Diffusers
- Hazardous Material Storage Containers

Alkegen has a wide range of FyreWrap protection materials available to provide passive fire protection solutions in a variety of applications in the commercial building, industrial facility and transportation industries.

For additional information about product performance or to identify the recommended product for your fire protection application, please contact the Alkegen Application Engineering Group at 716-768-6298.

Data are average results of tests conducted under standard procedures and are subject to variation. Results should not be used for specification purposes.



The following are registered trademarks of Alkegen: FyreWrap, Insulfrax, XFP, Lo-Con, Moist Pak-D, Fiberfrax, Durablanket, and Duraboard.

The test data shown are average results of tests conducted under standard procedures and are subject to variation. Results should not be used for specification purposes. Product Information Sheets are periodically updated by Alkegen. Before relying on any data or other information in this Product Information Sheet, you should confirm that it is still current and has not been superseded. A Product Information Sheet that has been superseded may contain incorrect, obsolete and/or irrelevant data and other information.

Form A-5251
Effective 07/23
© 2023 Alkegen
All Rights Reserved

Alkegen
Headquarters
5215 N. O'Connor Blvd, Suite 2300
Irving, TX 75039
Telephone: 716-768-6298
Website: www.alkegen.com
Email: Info@alkegen.com

