

LBP Moldafrax Pigtails System

DESCRIPTION

The LBP Moldafrax Pigtails System represents an innovative engineering solution designed to insulate the Inlet and Outlet Pigtail areas in petrochemical furnaces. This system uses rigid vacuum-formed tubes, specifically adapted to each project.

The main advantage of this system is the speed of installation due to the elimination of the need for metalworking services. Since the pipes are coated with a specially developed coating to resist moisture from adverse weather conditions or cleaning processes, as well as preventing the spread of flames, there is no need to apply sheet metal finishing.

UNIQUE FEATURES OF THE SYSTEM

- Customized design for highly complex geometries;
- Low Bio-persistent material (AES wool)
- Formulation specially developed to withstand the aggressiveness required by each application;
- Simple and fast fastening system;
- Temperature class: 1100 °C
- Special coating that adds weather resistance and prevents the spread of flames.
- **Meets ATSM C795, ASTM C692 and ASTM C871**

“Standard Specification for Thermal Insulation for Use in Contact with Austenitic Stainless Steel”

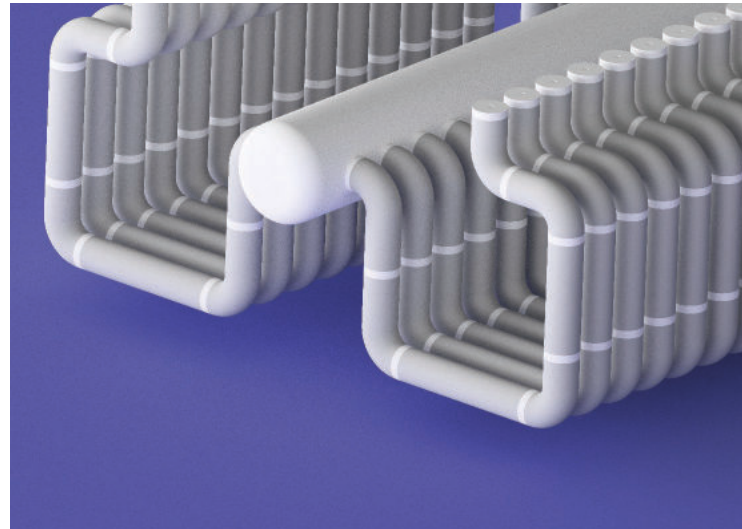

TYPICAL SCHEME

Stainless Steel Clamps for fixing

Weather & Fire Retardant Coat

LBP Moldafrax Shapes
(outer layer)

Insulfrax blanket (inner layer)

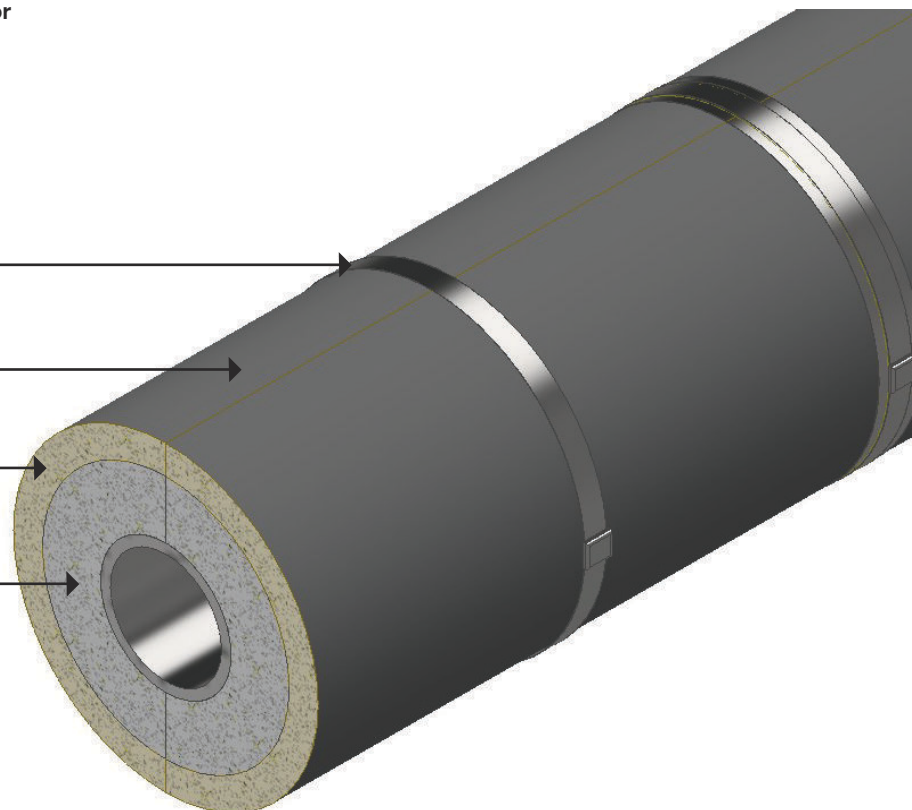

Product Information Sheet



LBP Moldafrax Pigtails System

CHEMICAL PROPERTIES

Vacuum-formed shapes are resistant to attack from most corrosive agents, except for hydrofluoric and phosphoric acids and concentrated alkalis. Vacuum-formed shapes are also resistant to both oxidation and reduction. If exposed to water or steam, their thermal and physical properties are restored after drying.

VACUUM FORMED PROPERTIES

Nominal Density	285 Kg/m ³	17.8 pcf
Temperature Rating	1100 °C	2000 F
Melting Point	> 1360 °C	> 2480 F
Linear Shrinkage - 24h @ 982 °C	1.8 %	
Linear Shrinkage - 24h @ 1260 °C	3.5 %	
Typical Rupture Modulus	12.4 N/m ²	
Compression as received 24h @ 1260°C	5 %	

Thermal Conductivity

	W / m . K	BTU.in/h.ft ² .F
@ 200 °C (392 F)	0.049	0.34
@ 400 °C (752 F)	0.068	0.47
@ 600 °C (1112 F)	0.094	0.65
@ 800 °C (1472 F)	0.130	0.90
@ 1000 °C (1832 F)	0.170	1.18

The Temperature Rating of Insulfrax® products is determined based on the criterion of irreversible linear change, not by the melting point.

The information contained in this publication is for illustrative purposes only and is not intended to create any contractual obligation. Further information and advice regarding specific details of the products described should be obtained in writing from a Alkegen Corporation company.

The test data shown are average results of tests conducted under standard procedures and are subject to variation. Results should not be used for specification purposes. Product Information Sheets are periodically updated by Alkegen. Before relying on any data or other information in this Product Information Sheet, you should confirm that it is still current and has not been superseded. A Product Information Sheet that has been superseded may contain incorrect, obsolete and/or irrelevant data and other information.

Form A-6140
Effective 07/25
© 2025 Alkegen
All Rights Reserved

LBP BLANKET PROPERTIES

	Unit	
Nominal Density	Kg/m ³	96–128
Temperature Rating°C	°C	1100
Melting Point	°C	> 1360
Linear Shrinkage - 24h @ 1100 °C	%	2.3

THERMAL CONDUCTIVITY

	96 kg/m ³ (6 pcf)	128 kg/m ³ (8 pcf)
	W / m.K (BTU.in/h.ft ² .F)	
@ 400 °C (752 F)	0.090 (0.62)	0.080 (0.55)
@ 600 °C (1112 F)	0.140 (0.97)	0.120 (0.83)
@ 800 °C (1472 F)	0.200 (1.39)	0.180 (1.25)
@ 1000 °C (1832 F)	0.290 (2.01)	0.280 (1.94)

COATING

	Unit	
Nominal Density	Kg/L	1.28
Solids content by weight	%	68.9
Flame spread (ASTM E84)	%	0
Weather Resistance	-	✓

Alkegen

Headquarters

5215 N. O'Connor Blvd, Suite 2300
Irving, TX 75039
Telephone: 716-768-6500
Website: www.alkegen.com
Email: info@alkegen.com

